



Accessories



Hardy Spicer, 17-31 Discovery Road, Dandenong South, Victoria, 3175
Toll free Ph: **1300 304 673**
www.hardyspicer.com.au

DISCLAIMER

Disclaimer

The information and dimensions listed in these catalogues is correct to the best of our knowledge and belief, having been compiled from reliable and official sources of information. However Hardy Spicer (HS Company Pty Ltd) accepts no responsibility for possible errors, omissions or unsuitable parts being listed or fitted to any vehicle. Dimensions listed are nominal throughout.

Due to our continuous product and range development we reserve the right to alter the specification without prior notice.

We welcome any feedback re suspected errors or omissions to the information enclosed. We can be contacted via email hspicer@hardyspicer.com.au

Or via Ph 03 9794 1900 or Fax 03 97069928

Alternatively via mail at PO Box 4262, Dandenong South, Vic. 3164.

Hydraulic Accessories

www.hardyspicer.com.au

Document No:	HSHYDCAT
Issue:	10
Issue Date:	01/09/2017

ACCESSORIES

CONTENTS

DESCRIPTION:

HOSE MERCHANDISERS.....	D:7-3
ASSORTMENT PACKS.....	D:7-4
BALL VALVES - HIGH PRESSURE.....	D:7-6
BALL VALVES - LOW PRESSURE.....	D:7-7
BALL VALVES - MINI BRASS.....	D:7-9
CHECK VALVES.....	D:7-10
PIPE CLAMPS.....	D:7-11
SPIRAL GUARD COVER.....	D:7-14
WIRE ARMOUR.....	D:7-15
HARDY SLEEVE.....	D:7-16
HEAT & FLAME PROTECTION.....	D:7-18
NYLON PROTECTIVE SLEEVE.....	D:7-19
LIFEGUARD.....	D:7-20
SHRINK BANDS.....	D:7-21
BEND RESTRICTORS.....	D:7-21
HOSE CLAMPS - S/S WORM DRIVE.....	D:7-22
SUPER CLAMPS.....	D:7-23
"P" CLAMPS.....	D:7-26
PRESSURE GAUGES.....	D:7-28
TEST POINTS.....	D:7-30
TEST HOSES.....	D:7-32
HYDRAULIC OIL.....	D:7-33
CABLE TIES.....	D:7-34
HOSE CLEANING PROJECTILES.....	D:7-34
SPILL KITS & SPILL CONTROL.....	D:7-35
TOOLS AND EQUIPMENT.....	D:7-38

www.hardyspicer.com.au

Document No:	HSHYDCAT
Issue:	10
Issue Date:	01/09/2017

ACCESSORIES

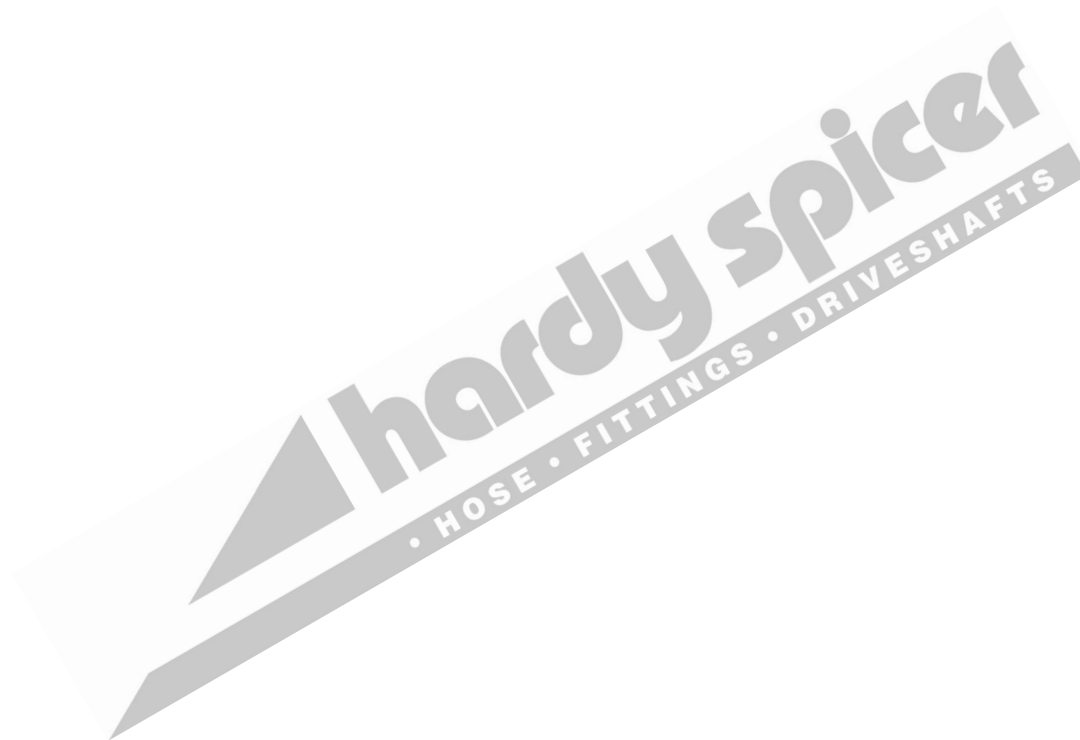

Hydraulic Accessories

www.hardyspicer.com.au

Document No:	HSHYDCAT
Issue:	10
Issue Date:	01/09/2017

ACCESSORIES

VACUUM & FUEL LINE MERCHANDISER



Part No: **HS-91140**

Description: Fuel line and Vacuum hose display stand including hose. Suitable for use on fuel lines, PCV and EEC systems. Includes three popular hoses for vacuum applications, window washers and radiator overflows.

Contents:

Fuel Line	
FUEL-LINE-27002	1/4" Hose
FUEL-LINE-27003	5/16" Hose
FUEL-LINE-27004	3/8" Hose
Vacuum Hose	
VACUUM-27042	5/32" Hose
VACUUM-27043	7/32" Hose
VACUUM-27044	1/4" Hose

AIR BRAKE HOSE ASSEMBLIES



Factory made assemblies to meet the rigorous conditions of today's heavy duty truck market. 1/2" hose assemblies ranging from 18 to 72 inches in length, fitted with high quality brass 3/8" male pipe fitting on one end and 3/8" female air brake swivel with a 3/8" male pipe adaptor on the other end.

Part Number	Length inches	Length mm
ABHA-18	18	457
ABHA-20	20	508
ABHA-24	24	609
ABHA-28	28	711
ABHA-30	30	762
ABHA-32	32	812
ABHA-36	36	914
ABHA-42	42	1066
ABHA-48	48	1219
ABHA-60	60	1524
ABHA-72	72	1828

www.hardyspicer.com.au

Document No:	HSHYDCAT
Issue:	10
Issue Date:	01/09/2017

ACCESSORIES

ASSORTMENT PACKS



Part No: **HS-KIT-ORING**
 Description: O-Ring assortment kit containing 16 assorted o-rings to suit SAE Flanges, UN Threads and Flat Face adaptors.

O-RING ASSORTMENT KIT CONTENTS

Flat Face Sealing O-Rings		
Part No.	Description	Qty
UOR-07	4OR	10
UOR-09	6OR	10
UOR-12	8OR	10
UOR-14	10OR	10
UOR-17	12OR	10
UOR-21	16OR	10
UOR-26	20OR	10

UN Thread O-Rings		
Part No.	Description	Qty
OOR-09	4ORFF	10
OOR-11	6ORFF	10
OOR-13	8ORFF	10
OOR-16	10ORFF	10
OOR-19	12ORFF	10
OOR-23	16ORFF	10

SAE Flange O-Rings		
Part No.	Description	Qty
FOR-12	12FLOR	10
FOR-16	16FLOR	10
FOR-20	20FLOR	10



Part No: **HS-KIT-IFCM-1**
 Description: Fuel line hose clamp kit. For use on fuel injection hose, transmission hose and other small hose applications.

FUEL LINE HOSE CLAMP KIT CONTENTS

Fuel Injection Clamps		
Part No.	Clamp Range	Qty
	11-13mm	10
	13-15mm	20
	14-16mm	10

Perforated Band Clamps		
Part No.	Clamp Range	Qty
	6-16mm	20
	7-17mm	20
	8-22mm	20



Part No: **HS-KIT-ICCM-1**
 Description: Hose connector and clamp pack Suitable for hose replacement and repairs on cooling systems

HOSE CLAMP & CONNECTOR KIT CONTENTS

Plastic Hose Connectors			
Part No.	Type	O.D.	Qty
	Straight	12.7mm	5
	Straight	15-9mm	5
	Straight	19mm	5
	Elbow	12.7mm	5
	Elbow	15-9mm	5
	Elbow	19mm	5

Perforated Band Clamps		
Part No.	Clamp Range	Qty
	11-25mm	10
	13.27mm	10
	13.32mm	10
	18-38mm	10

Hydraulic Accessories

www.hardyspicer.com.au

Document No:	HSHYDCAT
Issue:	10
Issue Date:	01/09/2017

ACCESSORIES

ASSORTMENT PACKS



Part No: **HS-KIT-IPCM-1**

Description: Pipe retaining clamps for securing hose and tube. A Rubber liner on the clamp absorbs vibration and protects the hose or tube.

P CLAMP KIT CONTENTS

P Clamps		
Part No.	Clamp Diameter	Qty
P-CLAMP-06	6mm	10
P-CLAMP-10	10mm	10
P-CLAMP-13	13mm	10
P-CLAMP-16	16mm	10
P-CLAMP-19	19mm	10
P-CLAMP-22	22mm	10
P-CLAMP-25	25mm	10



Part No: **HS-KIT-BS1**

Description: Bonded Seal kit containing a popular range of seals ranging in size from 1/8" to 1 1/4".

BONDED SEAL KIT CONTENTS

P Clamps		
Part No.	Clamp Diameter	Qty
BS-02	1/8"	10
BS-04	1/4"	10
BS-06	3/8"	10
BS-08	1/2"	10
BS-10	5/8"	10
BS-12	3/4"	10
BS-16	1"	8
BS-20	1 1/4"	6

www.hardyspicer.com.au

Document No:	HSHYDCAT
Issue:	10
Issue Date:	01/09/2017

ACCESSORIES



2 WAY HIGH PRESSURE BALL VALVES

PART NUMBER	THREAD SIZE BSPP	DN DIAMETER	OPERATING PRESSURE BAR	BODY LENGTH mm / inch	NOTES
HBV04B	1/4"	6	500	71 / 2.795"	
HBV06B	3/8"	10	500	73 / 2.874"	
HBV08B	1/2"	13	500	83 / 3.268"	
HBV12B	3/4"	20	400	95 / 3.740"	
HBV16B	1"	25	350	112 / 4.409"	
HBV20B	1 1/4"	25	350	120 / 4.724"	
HBV24B	1 1/2"	25	350	124 / 4.882"	



3 WAY HIGH PRESSURE BALL VALVES

PART NUMBER	THREAD SIZE BSPP	DN DIAMETER	OPERATING PRESSURE BAR	BODY LENGTH mm / inch	NOTES
3HBV04B	1/4"	6	400	71 / 2.795"	
3HBV06B	3/8"	10	400	73 / 2.874"	
3HBV08B	1/2"	13	350	83 / 3.268"	
3HBV12B	3/4"	20	350	95 / 3.740"	
3HBV16B	1"	25	350	112 / 4.409"	
3HBV20B	1 1/4"	25	350	120 / 4.724"	
3HBV24B	1 1/2"	25	350	124 / 4.882"	

www.hardyspicer.com.au

Document No:	HSHYDCAT
Issue:	10
Issue Date:	01/09/2017

Hydraulic Accessories

ACCESSORIES



LOW PRESSURE BRASS BALL VALVES

PART NUMBER	THREAD SIZE BSPP	DN DIAMETER	OPERATING PRESSURE PSI / BAR	BODY LENGTH mm / inch	NOTES
BBVAGA006	1/4"	8	710 / 49	49 / 1.929"	
BBVAGA010	3/8"	10	710 / 49	52 / 2.047"	
BBVAGA012	1/2"	15	710 / 49	60 / 2.362"	
BBVAGA020	3/4"	20	570 / 39	68 / 2.677"	
BBVAGA025	1"	25	570 / 39	85 / 3.346"	
BBVAGA032	1 1/4"	32	430 / 29		
BBVAGA040	1 1/2"	40	430 / 29		
BBVAGA050	2"	50	360 / 25		



LOW PRESSURE BRASS BALL VALVES (M-F)

PART NUMBER	THREAD SIZE BSPP	DN DIAMETER	OPERATING PRESSURE PSI / BAR	BODY LENGTH mm / inch	NOTES
BBVAGAMF006	1/4"	8	710 / 49		
BBVAGAMF010	3/8"	10	710 / 49		
BBVAGAMF012	1/2"	15	710 / 49		
BBVAGAMF020	3/4"	20	570 / 39		
BBVAGAMF025	1"	25	570 / 39		
BBVAGAMF032	1 1/4"	32	430 / 29		
BBVAGAMF040	1 1/2"	40	430 / 29		

www.hardyspicer.com.au

Document No:	HSHYDCAT
Issue:	10
Issue Date:	01/09/2017

ACCESSORIES



LOW PRESSURE BRASS TEE HANDLE BALL VALVES

PART NUMBER	THREAD SIZE BSPP	DN DIAMETER	OPERATING PRESSURE PSI / BAR	BODY LENGTH mm / inch	NOTES
BBVAGAT006	1/4"	8	710 / 49		
BBVAGAT010	3/8"	10	710 / 49		
BBVAGAT012	1/2"	15	710 / 49		
BBVAGAT020	3/4"	20	570 / 39		
BBVAGAT025	1"	25	570 / 39		



STAINLESS STEEL BALL VALVES (1 PIECE)

PART NUMBER	THREAD SIZE BSPP	DN DIAMETER	OPERATING PRESSURE PSI / BAR	BODY LENGTH mm / inch	NOTES
SS1P006	1/4"	8	1000 / 69	39 / 1.535"	
SS1P010	3/8"	10	1000 / 69	43 / 1.693"	
SS1P012	1/2"	15	1000 / 69		
SS1P020	3/4"	20	1000 / 69	60 / 2.362"	
SS1P025	1"	25	1000 / 69	72 / 2.835"	
SS1P032	1 1/4"	32	1000 / 69		
SS1P040	1 1/2"	40	1000 / 69		
SS1P050	2"	50	1000 / 69		

316 Stainless Steel - includes locking device as standard.

www.hardyspicer.com.au

Document No:	HSHYDCAT
Issue:	10
Issue Date:	01/09/2017

ACCESSORIES

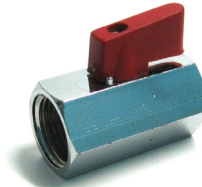

MINI BRASS BALL VALVES (F-F)

PART NUMBER	THREAD SIZE BSP	DN DIAMETER	OPERATING PRESSURE PSI	NOTES
MBVFF006	1/4"	8	220	
MBVFF010	3/8"	10	220	
MBVFF012	1/2"	15	220	
MBVFF020	3/4"	20	220	

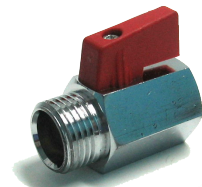

MINI BRASS BALL VALVES (M-F)

PART NUMBER	THREAD SIZE BSP	DN DIAMETER	OPERATING PRESSURE PSI	NOTES
MBVMF006	1/4"	8	220	
MBVMF010	3/8"	10	220	
MBVMF012	1/2"	15	220	
MBVMF020	3/4"	20	220	

www.hardyspicer.com.au

Document No:	HSHYDCAT
Issue:	10
Issue Date:	01/09/2017

ACCESSORIES



CHECK VALVES

PART NUMBER	THREAD SIZE BSP	DN DIAMETER	CRACKING PRESSURE BAR	MAX FLOW Lt / min	LENGTH mm / inch
CV2A05	1/4"	6	0.5	30	62 / 2.441"
CV3A05	3/8"	10	0.5	45	68 / 2.677"
CV4A05	1/2"	13	0.5	70	77 / 3.031"
CV6A05	3/4"	20	0.5	110	88 / 3.465"
CV8A05	1"	25	0.5	160	105 / 4.134"

Hydraulic Accessories



www.hardyspicer.com.au

Document No:	HSHYDCAT
Issue:	10
Issue Date:	01/09/2017

ACCESSORIES

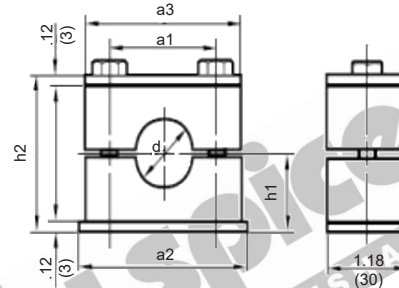

SINGLE LIGHT DUTY CLAMP

PART NUMBER	DIMENSIONS mm						
	d	a1	a2	a3	h1	h2	Bolt
SLDC-6	6.4	20	36	34	16	32	M6 x 30
SLDC-8	8	20	36	34	16	32	M6 x 30
SLDC-10	9.5	20	36	34	16	32	M6 x 30
SLDC-12	12.0	20	36	34	16	32	M6 x 30
SLDC-13	12.7	26	42	40	19.5	39	M6 x 35
SLDC-14	14	26	42	40	19.5	39	M6 x 35
SLDC-15	15	26	42	40	19.5	39	M6 x 35
SLDC-16	16	26	42	40	19.5	39	M6 x 35
SLDC-17	17.1	26	42	40	19.5	39	M6 x 35
SLDC-19	19	33	50	48	21.5	43	M6 x 40
SLDC-20	20	33	50	48	21.5	43	M6 x 40
SLDC-22	22	33	50	48	21.5	43	M6 x 40
SLDC-25	25.4	33	50	48	21.5	43	M6 x 40
SLDC-27	27	40	59	57	24	48	M6 x 45
SLDC-28	28	40	59	57	24	48	M6 x 45
SLDC-30	30	40	59	57	24	48	M6 x 45
SLDC-32	32	52	72	70	32	64	M6 x 60
SLDC-34	33.7	52	72	70	32	64	M6 x 60
SLDC-35	33.7	52	72	70	32	64	M6 x 60
SLDC-38	38	52	72	70	32	64	M6 x 60
SLDC-44	44.5	66	88	86	36	72	M6 x 70
SLDC-48	48.3	66	88	86	36	72	M6 x 70
SLDC-51	50.8	66	88	86	36	72	M6 x 70

www.hardyspicer.com.au

Document No:	HSHYDCAT
Issue:	10
Issue Date:	01/09/2017

ACCESSORIES

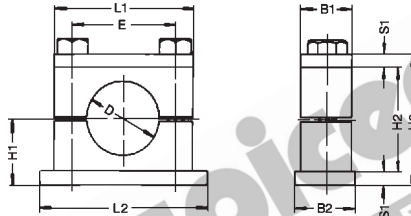

SINGLE HEAVY DUTY CLAMP

PART NUMBER	DIMENSIONS mm					
	d	e	l1	l2	h1	Bolt Size
SHDC-10	10.3	33.0	55	73	24	M10 x 45
SHDC-13	12.7	33.0	55	65	24	M10 x 45
SHDC-16	16.0	33.0	55	65	24	M10 x 45
SHDC-19	19.0	45.0	70	85	32	M10 x 60
SHDC-25	25.4	45.0	70	85	32	M10 x 60
SHDC-32	32.0	60.0	85	100	38	M10 x 70
SHDC-38	38.0	60.0	85	100	38	M10 x 70
SHDC-51	50.8	90.5	115	140	55	M12 x 100
SHDC-57	57	90.5	115	140	55	M12 x 100
SHDC-60	60.3	90.5	115	140	55	M12 x 100
SHDC-65	65	90.5	115	140	55	M12 x 100
SHDC-70	70	90.5	115	140	55	M12 x 100

* Larger clamps up to 406mm available on request

Hydraulic Accessories

www.hardyspicer.com.au

Document No:	HSHYDCAT
Issue:	10
Issue Date:	01/09/2017

ACCESSORIES

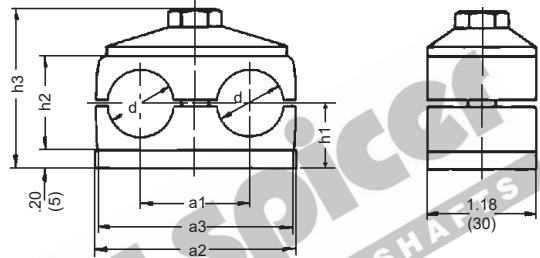

TWIN LIGHT DUTY CLAMP

PART NUMBER	DIMENSIONS mm							Bolts
	d	a1	a2	a3	h1	h2	h3	
TLDC-06	6.4	20	37	36	18.5	27	43	M6 x 35
TLDC-08	8	20	37	36	18.5	27	43	M6 x 35
TLDC-10	9.5	20	37	36	18.5	27	43	M6 x 35
TLDC-12	12	20	37	36	18.5	27	43	M6 x 35
TLDC-13	12.7	29	55	53	18	26	43.5	M8 x 35
TLDC-14	14	29	55	53	18	26	43.5	M8 x 35
TLDC-15	15	29	55	53	18	26	43.5	M8 x 35
TLDC-16	16	29	55	53	18	26	43.5	M8 x 35
TLDC-17	17.1	29	55	53	18	26	43.5	M8 x 35
TLDC-19	19	36	70	67	23.5	37	54.5	M8 x 45
TLDC-20	20	36	70	67	23.5	37	54.5	M8 x 45
TLDC-22	22	36	70	67	23.5	37	54.5	M8 x 45
TLDC-25	25.4	36	70	67	23.5	37	54.5	M8 x 45
TLDC-28	28	45	85	82	26	42	59.5	M8 x 50
TLDC-30	30	45	85	82	26	42	59.5	M8 x 50
TLDC-32	32	56	110	106	32	54	71.5	M8 x 60
TLDC-38	38	56	110	106	32	54	71.5	M8 x 60
TLDC-42	42	56	110	106	32	54	71.5	M8 x 60

www.hardyspicer.com.au

Document No:	HSHYDCAT
Issue:	10
Issue Date:	01/09/2017

ACCESSORIES

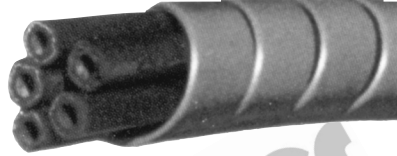

SPIRALGUARD

FEATURES:

- Exceptional anti-crushing performance.
- High abrasion resistance and proven in arduous conditions.
- Self-lubricating to reduce wear on hose and cable.
- Easy to fit and suitable for wrapping single or multiple bundles.
- Good resistance to UV rays and suitable for mining, quarry, forestry, and most hydraulic hose applications.

PART NUMBER	APPLICATION				
	I.D.	1-Wire	2-Wire	Multi Spiral	Hose OD Range
SGX-12	12mm	-03	-	-	9mm - 12mm
SGX-16	16mm	-04	-04	-	12mm - 17mm
SGX-20	20mm	-06	-04	-06	16mm - 22mm
		-	-06	-	
SGX-25	25mm	-08	-08	-08	22mm - 28mm
		-10	-10	-10	
SGX-32	32mm	-12	-10	-12	27mm - 33mm
		-	-12	-	
SGX-40	40mm	-16	-16	-16	33mm - 42mm
SGX-50	50mm	-20	-20	-20	42mm - 55mm
		-24	-	-	
SGX-63	63mm	-32	-24	-24	52mm - 65mm
SGX-75	75mm	-	-32	-32	65mm - 80mm
SGX-90	90mm	Hose Looms 80mm - 150mm Diameter			
SGX-110	110mm	Hose Looms 1500mm and above			

Standard colour is black, blue and yellow are available on request.

FRAS (FLAME RESISTANT & ANTI-STATIC)

PART NUMBER	APPLICATION				
	I.D.	1-Wire	2-Wire	Multi Spiral	Hose OD Range
SGX-12FRAS	12mm	-03	-	-	9mm - 12mm
SGX-16FRAS	16mm	-04	-04	-	12mm - 17mm
SGX-20FRAS	20mm	-06	-04	-06	16mm - 22mm
		-	-06	-	
SGX-25FRAS	25mm	-08	-08	-08	22mm - 28mm
		-10	-10	-10	
SGX-32FRAS	32mm	-12	-10	-12	27mm - 33mm
		-	-12	-	
SGX-40FRAS	40mm	-16	-16	-16	33mm - 42mm
SGX-50FRAS	50mm	-20	-20	-20	42mm - 55mm
		-24	-	-	
SGX-63FRAS	63mm	-32	-24	-24	52mm - 65mm
SGX-75FRAS	75mm	-	-32	-32	65mm - 80mm
SGX-90FRAS	90mm	Hose Looms 80mm - 150mm Diameter			
SGX-110FRAS	110mm	Hose Looms 1500mm and above			

www.hardyspicer.com.au

Document No:	HSHYDCAT
Issue:	10
Issue Date:	01/09/2017

ACCESSORIES



WIRE ARMOUR

Part Number	Nominal ID		Comments
	mm	inch	
WA-02	15.10	0.594"	
WA-03	17.57	0.692"	
WA-04	18.60	0.732"	
WA-05	21.30	0.839"	
WA-06	23.00	0.906"	
WA-07	25.50	1.004"	
WA-08			
WA-09	29.00	1.142"	
WA-10	32.80	1.291"	
WA-12	41.00	1.614"	
WA-15	53.50	2.106"	
WA-16			
WA-18	60.00	2.362"	
WA-20	73.50	2.894"	
WA-32			

Coils come in 5 metre lengths.

www.hardyspicer.com.au

Document No:	HSHYDCAT
Issue:	10
Issue Date:	01/09/2017

ACCESSORIES



HARDY SLEEVE

Hardy Sleeve meets and exceeds:

- Line of sight operator specification EN982 & EN414.
- Requirements of NSW MDG41 Guideline for fluid power safety at mines.
- Abrasion resistance standards to ISO 6945 & ASTM D6770.
- Flame Resistance to MSHA IC 234/0.
- Electrical conductivity requirement ISO 8031.
- Ultra tight construction contains oil spillage from pin hole leaks.
- Densely twisted polyamide 6 yarn offers optimum UV and abrasion protection.
- Melting Point 215°C (420°F).
- Tested to 250,000 Abrasion Cycles.

Note: Using Hardy Sleeve in abrasion applications WILL compromise the sleeve's burst protection properties

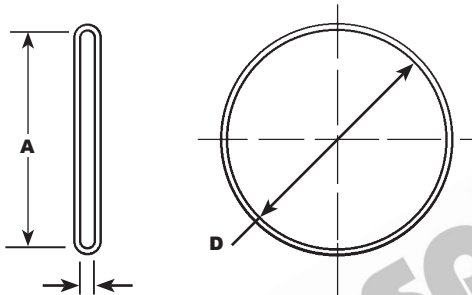

PART NUMBER	SLEEVE I.D. D - inch/mm	INSIDE FLAT A - inch/mm	DESCRIPTION	COMMENTS
HS-17	0.669" / 17	1.181" / 30		
HS-20	0.787" / 20	1.338" / 34		
HS-23	0.905" / 23	1.535" / 39		
HS-25	0.984" / 25	1.653" / 42		
HS-27	1.063" / 27	1.772" / 45		
HS-31	1.220" / 31	2.047" / 52		
HS-36	1.417" / 36	2.244" / 57		
HS-40	1.575" / 40	2.598" / 66		
HS-44	1.732" / 44	2.835" / 72		
HS-47	1.850" / 47	3.031" / 77		
HS-55	2.165" / 55	3.504" / 89		
HS-60	2.362" / 60	3.819" / 97		
HS-73	2.874" / 73	4.646" / 118		
HS-75	2.953" / 75	4.764" / 121		
HS-93	3.661" / 93	5.866" / 149		
HS-112	4.409" / 112	7.047" / 179		

www.hardyspicer.com.au

Document No:	HSHYDCAT
Issue:	10
Issue Date:	01/09/2017

Hydraulic Accessories

HARDY SLEEVE HOSE SELECTION MATRIX

Hose Part #	HS-17	HS-20	HS-23	HS-25	HS-27	HS-31	HS-36	HS-40	HS-44	HS-47	HS-55	HS-60	HS-73	HS-75	HS-93	HS-112
ACP-20																
ACP-24																
ACP-32																
EFG3K-24																
EFG3K-32																
EFG4K-06																
EFG4K-08																
EFG4K-10																
EFG4K-12																
EFG4K-16																
EFG4K-20																
EFG6K-06																
EFG6K-08																
EFG6K-10																
EFG6K-12																
EFG6K-16																
EFG6K-20																
EFG6K-24																
EFG6K-32																
G1-03																
G1-04																
G1-05																
G1-06																
G1-08																
G1-10																
G1-12																
G1-16																
G1-20																
G1-24																
G1-32																
G2-03																
G2-04																
G2-06																
G2-08																
G2-10																
G2-12																
G2-16																
G2-20																
G2-24																
G2-32																
J2AT-04																
J2AT-06																
M5K-04																
M5K-06																
M5K-08																
M6K-04																

www.hardyspicer.com.au

Document No:	HSHYDCAT
Issue:	10
Issue Date:	01/09/2017

ACCESSORIES



HEAT & FLAME PROTECTION

FEATURES:

- Completely non-asbestos, heat resistant, protective coating.
- Special silicone coating to withstand a broad range of solvents and fuels.
- Easy to fit, with only hose clamps or wire ties required for fastening.
- HTG series - Knitted coated fibreglass meets SAE AS1072A specification.
- Temperature range for HTG series: -54°C to +260°C (-65°F to +500°F).
- HTGH series - Braided coated fibreglass meets SAE AS1055 specification.
- Temperature range for HTGH series: 260°C to 1093°C (500°F to 2000°F).

PART NUMBER	SLEEVE I.D.		DESCRIPTION	COMMENTS
	inch	mm		
HTG-12	0.750"	19.05	7277-1579	
HTG-14	0.880"	22.35	7277-1581	
HTG-16	1.000"	25.40	7277-1196	
HTG-18	1.120"	28.45	7277-1197	
HTG-22	1.380"	35.05	7277-1584	
HTG-24	1.500"	38.10	7277-1585	
HTG-26	1.620"	41.15	7277-1586	
HTG-28	1.750"	44.45	7277-1587	
HTG-32	2.000"	50.80	7277-1589	
HTG-34	2.120"	53.85	7277-1590	
HTG-36	2.250"	57.15	7277-1591	
HTG-38	2.380"	60.45	7277-1592	
HTG-44	2.750"	69.85	7277-1595	
HTG-48	3.000"	76.20	7277-1597	
HTGH-24	1.500"	38.10	7277-1611	High temperature
HTGH-28	1.750"	44.15	7277-1604	High temperature
HTGH-36	2.250"	57.15	7277-1606	High temperature
HTGH-44	2.750"	69.85	7277-1607	High temperature
HTGH-52	3.250"	82.55	7277-1608	High temperature
HTGH-60	3.750"	95.25	7277-1609	High temperature

Selection Chart

HOSE SIZE	C5C, C5D, C5M	C5E	G1	G2	M3K	M2T, M4K, M5K, M6K	C12M, G4K	C12, G3K	G5K, G6K	GMV
-04	HTG-12	HTG-12	HTG-12	HTG-14	HTG-12	HTG-12				
-05	HTG-14	HTG-14	HTG-14		HTG-14					
-06	HTG-16		HTG-16	HTG-16	HTG-14	HTG-16	HTG-16		HTG-16	
-08	HTG-16	HTG-16	HTG-18	HTG-18	HTG-16	HTG-16	HTG-18		HTG-18	
-10	HTG-18	HTG-18	HTG-18	HTG-18	HTG-18	HTG-18			HTG-22	
-12	HTG-22	HTG-18	HTG-22	HTG-22	HTG-22	HTG-22	HTG-24		HTG-24	HTG-24
-16	HTG-24	HTG-24	HTG-26	HTG-28	HTG-28	HTG-26	HTG-28		HTG-28	HTG-28
-20	HTG-28	HTG-28	HTG-32	HTG-32			HTG-32		HTG-34	HTG-32
-24	HTG-32		HTG-36	HTG-38				HTG-38	HTG-40	HTG-36
-32	HTG-38		HTG-44	HTG-48				HTG-44	HTG-48	HTG-44
-36	HTG-50									HTG-48
-40										HTG-52
-48										HTG-60

www.hardyspicer.com.au

Document No:	HSHYDCAT
Issue:	10
Issue Date:	01/09/2017

ACCESSORIES

Determining the size of a sleeve
 $D = \text{Nominal I.D.} = A \times 2 \div 3.14$

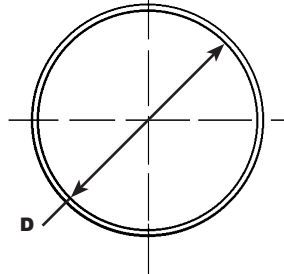
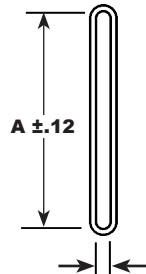

NYLON PROTECTIVE SLEEVE

PART NUMBER	SLEEVE I.D. D - inch/mm	INSIDE FLAT A - inch/mm	DESCRIPTION	COMMENTS
HNG-14	0.900" / 22.86	1.420" / 36.07	7277-1010	
HNG-16	1.060" / 26.92	1.670" / 42.42	7277-1011	
HNG-20	1.220" / 30.99	1.920" / 48.77	7277-1012	
HNG-24	1.420" / 36.07	2.240" / 56.90	7277-1013	
HNG-28	1.810" / 45.98	2.850" / 72.39	7277-1014	
HNG-32	2.190" / 55.63	3.440" / 87.38	7277-1015	
HNG-38	2.380" / 60.45	3.740" / 95.00	7277-1016	
HNG-42	2.620" / 66.55	4.120" / 104.65	7277-1018	
HNG-46	2.880" / 73.15	4.530" / 115.06	7277-1024	
HNG-64	4.400" / 111.76	6.910" / 175.51	7277-1276	

NYLON PROTECTIVE SLEEVE MATRIX

Nylon Sleeve Part Number	I.D. Inches	I.D. mm	HOSE APPLICATIONS								Shrink Band Clamp		
			G1, G1H	G2, G2H, G2L, G2XH M6K, J2AT ACP	EFG3K EFG4K	EFG5K EFG6K	M3K	M4K, M5K M2T	GMV R4	C5C, C5D C5M			
HNG-10	0.68	17.27							-03 / -04		-04		
HNG-14	0.90	22.86	-04 / -06	-04					-05 / -06	-04 / -05		-05 / -06	SBC-19
HNG-16	1.06	26.92	-08	-06	-06	-06			-08	-06		-08	SBC-22
HNG-20	1.22	30.99	-10	-08 / -10	-08	-08			-10	-08		-10	SBC-29
HNG-24	1.42	36.07	-12	-12	-10	-10			-12	-10 / -12		-12	SBC-34
HNG-26	1.59	40.39			-12	-12					-12	-16	
HNG-28	1.81	45.97	-16	-16	-16	-16			-16	-16	-16	-20	SBC-41
HNG-32	2.19	55.63	-20								-20	-24	SBC-54
HNG-38	2.38	60.45	-24	-20	-20	-20					-24		SBC-60
HNG-42	2.62	66.55		-24	-24	-24						-32	SBC-73
HNG-46	2.88	73.15	-32								-32		SBC-73
HNG-56													
HNG-64	4.40	111.76									-48		

www.hardyspicer.com.au

Document No:	HSHYDCAT
Issue:	10
Issue Date:	01/09/2017

ACCESSORIES



LIFE GUARD - LINE OF SIGHT PROTECTION

PART NUMBER	GATES DESCRIPTION	I.D. inch / mm	HOSE SIZE	COLLARS	
				ALUM.	S/STEEL
LG-14	7277-1850	0.709" / 18.0	1/4"	LG-C-AL-04-06	LG-C-SS-04-06
LG-16	7277-1851	0.906" / 23.0	3/8"	LG-C-AL-04-06	LG-C-SS-04-06
LG-20	7277-1852	1.063" / 27.0	1/2"	LG-C-AL-08	LG-C-SS-08
LG-20-5K	7277-1952	1.220" / 31.0	1/2"	LG-C-AL-08	LG-C-SS-08
LG-22	7277-1853	1.260" / 32.0	5/8"	LG-C-AL-10	LG-C-SS-10
LG-26	7277-1854	1.500" / 38.1	3/4"	LG-C-AL-12	LG-C-SS-12
LG-26-4K	7277-1964	1.590" / 40.4	3/4"	LG-C-AL-12	LG-C-SS-12
LG-32	7277-1965	1.990" / 50.5	1"	LG-C-AL-16	LG-C-SS-16

Hydraulic Accessories

www.hardyspicer.com.au

Document No:	HSHYDCAT
Issue:	10
Issue Date:	01/09/2017

ACCESSORIES



SHRINK BAND CLAMPS

PART NUMBER	NOMINAL HOSE I.D. inch / mm	SUIT HOSE O.D. mm	DESCRIPTION	COMMENTS
SBC-15	0.250" / 6.40	12.70 - 17.46	7405-4001	
SBC-19	0.375" / 9.50	17.46 - 20.64	7405-4002	
SBC-22	0.500" / 12.70	20.64 - 23.81	7405-4003	
SBC-25	0.625" / 15.90	23.81 - 26.98	7405-4004	
SBC-29	0.750" / 19.00	26.98 - 30.16	7405-4005	
SBC-34	1.000" / 25.40	30.16 - 38.10	7405-4006	
SBC-41	1.250" / 31.80	38.10 - 44.50	7405-4007	
SBC-48	1.500" / 38.10	44.50 - 50.80	7405-4008	
SBC-54	1.750" / 44.50	50.80 - 57.60	7405-4009	
SBC-60	2.000" / 50.80	57.60 - 63.50	7405-4010	
SBC-67	2.250" / 57.60	63.50 - 69.90	7405-4011	
SBC-73	2.500" / 63.50	69.90 - 76.20	7405-4012	
SBC-79	2.750" / 69.90	76.20 - 82.55	7405-4013	
SBC-86	3.000" / 76.20	82.55 - 88.90	7405-4014	
SBC-90	3.125" / 79.40	88.90 - 92.10	7405-4015	



VINYL BEND RESTRICTOR

PART NUMBER	LENGTH inch / mm	I.D. inch / mm	HOSE SIZE & TYPE
HBR-04	5.500" / 139.7	0.630" / 16.0	G1-04, G1H-04, G2-04, M3K-04, M2T-04
HBR-06	5.984" / 152.0	0.728" / 18.5	G1-06, G1H-06, M3K-06, M2T-06, GT7-06
HBR-08	6.969" / 177.0	0.839" / 21.3	G1-08, G1H-08
HBR-10	8.976" / 228.0	1.000" / 25.4	G1-10, G1H-10, M2T-10

www.hardyspicer.com.au

Document No:	HSHYDCAT
Issue:	10
Issue Date:	01/09/2017

ACCESSORIES



HOSE CLAMPS (Stainless Steel Band)

Part Number	Range (mm)		Clamp Width	Part Number	Range (mm)		Clamp Width
	From	To			From	To	
MAH4	6	16	10	HSS60	84	108	15
HSS6	11	20	15	HSS64	91	114	15
HSS8	12	23	15	HSS72	48	127	15
HSS10	11	27	15	HSS80	64	140	15
HSS12	17	32	15	HSS88	79	152	15
HSS16	21	38	15	HSS96	92	165	15
HSS20	21	45	15	HSS104	105	178	15
HSS24	27	51	15	HSS128	143	216	15
HSS28	33	57	15	HSS152	181	254	15
HSS32	40	64	15	HSS188	238	311	16
HSS36	46	70	15	HSS200	257	330	16
HSS40	52	76	15	HSS212	276	350	16
HSS44	59	83	15	HSS224	295	368	16
HSS48	65	90	15	HSS236	315	387	16
HSS52	71	95	15	HSS248	334	406	16
HSS56	78	102	15	HSS312	435	508	16

Full Stainless Steel and Plated options available on request.

Hydraulic Accessories

www.hardyspicer.com.au

Document No:	HSHYDCAT
Issue:	10
Issue Date:	01/09/2017

ACCESSORIES

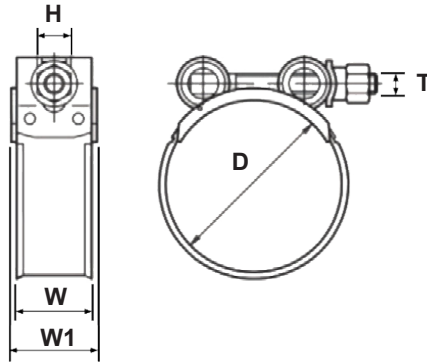

SUPER CLAMPS

HS PART	RANGE (MM) D	THREAD T	HEX H	WIDTH W	W1	MAX TORQUE (Nm)	MAX PRESSURE (BAR)
SW1-17	17-19	M5	8	18	19.8	4.5	48
SW1-19	20-22	M5	8	18	19.8	4.5	48
SW1-23	23-25	M5	8	18	19.8	4.5	45
SW1-25	26-28	M5	8	18	19.8	4.5	45
SW1-29	29-31	M6	10	20	22	8	42
SW1-31	32-35	M6	10	20	22	8	42
SW1-34	34-37	M6	10	20	22	8	40
SW1-36	36-39	M6	10	20	22	8	40
SW1-40	40-43	M6	10	20	22	8	40
SW1-43	44-47	M7	11	22	24.5	16	44
SW1-47	48-51	M7	11	22	24.5	16	44
SW1-51	52-55	M7	11	22	24.5	16	40
SW1-55	56-59	M7	11	22	24.5	16	40
SW1-59	60-63	M7	11	22	24.5	16	36
SW1-63	64-67	M7	11	22	24.5	16	36
SW1-67	68-73	M8	13	24	26.5	25	28
SW1-73	74-79	M8	13	24	26.5	25	28
SW1-79	80-85	M8	13	24	26.5	25	28
SW1-85	86-91	M8	13	24	26.5	25	20
SW1-91	92-97	M8	13	24	26.5	25	20
SW1-97	98-103	M8	13	24	26.5	25	20
SW1-104	104-112	M8	13	24	26.5	25	12
SW1-112	113-121	M8	13	24	26.5	25	12
SW1-121	122-130	M8	13	24	26.5	25	12
SW1-130	131-139	M10	17	26	29	50	9
SW1-140	140-148	M10	17	26	29	50	9
SW1-150	149-161	M10	17	26	29	50	9
SW1-162	162-174	M10	17	26	29	50	6
SW1-174	175-187	M10	17	26	29	50	6
SW1-187	188-200	M10	17	26	29	50	6
SW1-200	201-213	M10	17	26	29	50	3

www.hardyspicer.com.au

Document No:	HSHYDCAT
Issue:	10
Issue Date:	01/09/2017

ACCESSORIES

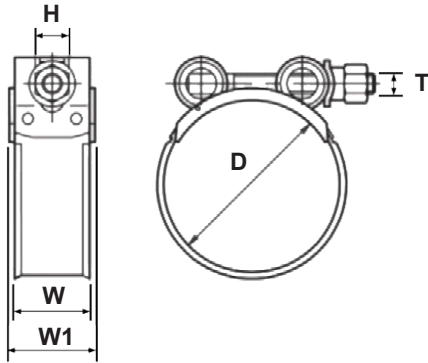

SUPER CLAMPS (Stainless Steel Band)

HS PART	RANGE (MM) D	THREAD T	HEX H	WIDTH W	W1	MAX TORQUE (Nm)	MAX PRESSURE (BAR)
SW2-17	17-19	M6	8	18	19.8	10	45
SW2-19	19-21	M6	8	18	19.8	10	45
SW2-21	21-23	M6	8	18	19.8	10	45
SW2-23	23-25	M6	8	18	19.8	10	45
SW2-25	25-27	M6	8	18	19.8	10	45
SW2-27	27-29	M6	8	18	19.8	10	45
SW2-29	29-31	M7	10	20	22	13	40
SW2-31	31-34	M7	10	20	22	13	40
SW2-34	34-37	M7	10	20	22	13	40
SW2-37	37-40	M7	10	20	22	13	40
SW2-40	40-43	M7	10	20	22	13	40
SW2-43	43-47	M7	10	20	22	16	36
SW2-47	47-51	M7	10	20	22	16	36
SW2-51	51-55	M7	10	20	22	16	36
SW2-55	55-69	M7	10	20	22	16	36
SW2-59	59-63	M7	10	20	22	16	36
SW2-63	63-68	M7	10	20	22	16	36
SW2-68	68-73	M8	13	25	27.5	30	28
SW2-73	73-79	M8	13	25	27.5	30	28
SW2-79	79-85	M8	13	25	27.5	30	20
SW2-85	85-91	M8	13	25	27.5	30	20
SW2-91	91-97	M8	13	25	27.5	30	20
SW2-97	97-104	M8	13	25	27.5	30	12
SW2-104	104-112	M8	13	25	27.5	30	12
SW2-112	112-121	M8	13	25	27.5	30	12
SW2-121	121-130	M8	13	25	27.5	30	9
SW2-130	130-140	M10	15	28	31	45	9
SW2-140	140-150	M10	15	28	31	45	9
SW2-150	150-162	M10	15	28	31	45	6
SW2-162	162-174	M10	15	28	31	45	6
SW2-174	174-187	M10	15	28	31	45	6
SW2-187	187-200	M10	15	28	31	45	6
SW2-200	200-213	M10	15	28	31	45	3

Hydraulic Accessories

www.hardyspicer.com.au

Document No:	HSHYDCAT
Issue:	10
Issue Date:	01/09/2017

ACCESSORIES

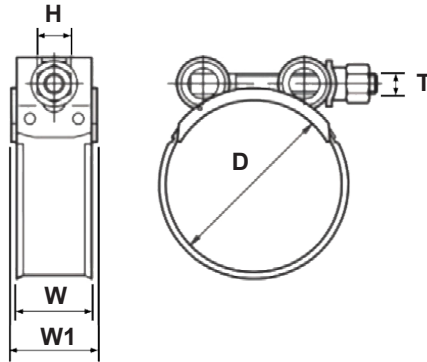

SUPER CLAMPS (Full Stainless Steel)

HS PART	RANGE (MM) D	THREAD T	HEX H	WIDTH W	W1	MAX TORQUE (Nm)	MAX PRESSURE (BAR)
SW4-17 #	17-19	M6	8	18	19.8	10	40
SW4-19 #	19-21	M6	8	18	19.8	10	40
SW4-21 #	21-23	M6	8	18	19.8	10	40
SW4-23 #	23-25	M6	8	18	19.8	10	40
SW4-25 #	25-27	M6	8	18	19.8	10	40
SW4-31 #	27-29	M6	8	18	19.8	10	40
SW4-29 #	29-31	M7	11	20	22	12	35
SW4-31 #	31-34	M7	11	20	22	12	35
SW4-34 #	34-37	M7	11	20	22	12	35
SW4-37 #	37-40	M7	11	20	22	12	35
SW4-40 #	40-43	M7	11	20	22	12	35
SW4-43 #	43-47	M7	11	20	22	12	35
SW4-47 #	47-51	M7	11	20	22	16	30
SW4-51 #	51-55	M7	11	20	22	16	30
SW4-55 #	55-69	M7	11	20	22	16	30
SW4-59 #	59-63	M7	11	20	22	16	30
SW4-63 #	63-68	M7	11	20	22	16	30
SW4-68 #	68-73	M8	13	25	27.5	30	20
SW4-73 #	73-79	M8	13	25	27.5	30	20
SW4-79 #	79-85	M8	13	25	27.5	30	20
SW4-85 #	85-91	M8	13	25	27.5	30	15
SW4-91 #	91-97	M8	13	25	27.5	30	15
SW4-97 #	97-104	M8	13	25	27.5	30	15
SW4-104 #	104-112	M8	13	25	27.5	30	10
SW4-112 #	112-121	M8	13	25	27.5	30	10
SW4-121 #	121-130	M8	13	25	27.5	30	10
SW4-130 #	130-140	M10	15	28	31	45	6
SW4-140 #	140-150	M10	15	28	31	45	6
SW4-150 #	150-162	M10	15	28	31	45	6
SW4-162 #	162-174	M10	15	28	31	45	3
SW4-174 #	174-187	M10	15	28	31	45	3
SW4-187 #	187-200	M10	15	28	31	45	3
SW4-200 #	200-213	M10	15	28	31	45	3

INDENT ITEM - Available on request

www.hardyspicer.com.au

Document No:	HSHYDCAT
Issue:	10
Issue Date:	01/09/2017

ACCESSORIES



P CLAMPS - PLASTIC COATED

Part Number	Clamp I.D. (Closed)		Bolt Hole Diameter	
	mm	inch	mm	inch
900729-18	6.35	0.250"	10.30	0.406"
900729-19	9.65	0.380"	10.30	0.406"
900729-01	11.18	0.440"	10.30	0.406"
900729-1	12.70	0.500"	10.30	0.406"
900729.2	14.22	0.560"	10.30	0.406"
900729-21	16.00	0.630"	10.30	0.406"
900729-3	17.53	0.690"	10.30	0.406"
900729-4	19.05	0.750"	10.30	0.406"
900729-5	20.57	0.810"	10.30	0.406"
900729-6	23.88	0.940"	10.30	0.406"
900729-23	25.40	1.000"	10.30	0.406"
900729-8	26.92	1.060"	10.30	0.406"
900729-9	28.70	1.130"	13.50	0.531"
900729-27	30.23	1.190"	13.50	0.531"
900729-24	31.75	1.250"	13.50	0.531"
900729-25	33.27	1.310"	13.50	0.531"
900729-10	38.10	1.500"	13.50	0.531"
900729-11	39.62	1.560"	13.50	0.531"
900729-12	44.45	1.750"	13.50	0.531"
900729-28	45.97	1.810"	13.50	0.531"
900729-13	50.80	2.000"	13.50	0.531"
900729-29	52.32	2.060"	13.50	0.531"
900729-14	57.15	2.250"	13.50	0.531"
900729-30	63.50	2.500"	13.50	0.531"
900729-31	66.80	2.630"	13.50	0.531"
900729-15	69.85	2.750"	13.50	0.531"
900729-16	73.15	2.880"	13.50	0.531"
900729-17	90.42	3.560"	13.50	0.531"

Hydraulic Accessories

www.hardyspicer.com.au

Document No:	HSHYDCAT
Issue:	10
Issue Date:	01/09/2017

ACCESSORIES



P CLAMPS - RUBBER COATED

Part Number	Clamp I.D. (Closed)		Bolt Hole Diameter	Band Width
	mm	inch	mm	mm
P-CLAMP-04	4.00	0.157	6	15
P-CLAMP-05	5.00	0.197	6	15
P-CLAMP-06	6.00	0.236	6	15
P-CLAMP-09	9.00	0.354	6	15
P-CLAMP-10	10.00	0.393	6	15
P-CLAMP-12	12.00	0.472	6	15
P-CLAMP-13	13.00	0.512	6	15
P-CLAMP-15	15.00	0.591	6	15
P-CLAMP-16	16.00	0.630	6	15
P-CLAMP-18	18.00	0.709	6	15
P-CLAMP-19	19.00	0.748	6	15
P-CLAMP-20	20.00	0.787	6	15
P-CLAMP-22	22.00	0.866	6	15
P-CLAMP-25	25.00	0.984	6	15
P-CLAMP-27	27.00	1.063	6	15
P-CLAMP-29	29.00	1.142	6	15
P-CLAMP-32	32.00	1.260	6	15
P-CLAMP-35	35.00	1.378	6	15
P-CLAMP-38	38.00	1.497	6	15
P-CLAMP-40	40.00	1.575	6	15
P-CLAMP-45	45.00	1.772	6	15
P-CLAMP-48	48.00	1.890	6	15
P-CLAMP-51	51.00	2.008	6	15
P-CLAMP-55	55.00	2.165	6	15
P-CLAMP-57	57.00	2.244	6	15
P-CLAMP-60	60.00	2.362	6	15
P-CLAMP-64	64.00	2.520	6	15
P-CLAMP-66	66.00	2.598	6	15
P-CLAMP-70	70.00	2.756	6	15

www.hardyspicer.com.au

Document No:	HSHYDCAT
Issue:	10
Issue Date:	01/09/2017

ACCESSORIES



MANOMETER PRESSURE GAUGES

Part Number	Diameter mm	Pressure		Thread	Thread Location
		Bar	PSI		
GAUGE-600-6-SLB	50	600	8702	DN10	Staplelock Gauge
PG63-0-04-PB	63	-1/0	-14.5/0	1/4" BSPP	Bottom
PG63-3-04-PB	63	-1/3	-14.5/43	1/4" BSPP	Bottom
PG63-4-04-PB	63	0/4	58	1/4" BSPP	Bottom
PG63-6-04-PB	63	0/6	87	1/4" BSPP	Bottom
PG63-10-04-PB	63	10	145	1/4" BSPP	Bottom
PG63-25-04-PB	63	25	362	1/4" BSPP	Bottom
PG63-40-04-PB	63	40	580	1/4" BSPP	Bottom
PG63-60-04-PB	63	60	870	1/4" BSPP	Bottom
PG63-100-04-PB	63	100	1450	1/4" BSPP	Bottom
PG63-250-04-PB	63	250	3625	1/4" BSPP	Bottom
PG63-400-04-PB	63	400	5801	1/4" BSPP	Bottom
PG63-600-04-PB	63	600	8702	1/4" BSPP	Bottom
PG63-0-04-PR	63	-1/0	-14.5/0	1/4" BSPP	Rear
PG63-3-04-PR	63	-1/3	-14.5/43	1/4" BSPP	Rear
PG63-6-04-PR	63	0/6	87	1/4" BSPP	Rear
PG63-10-04-PR	63	10	145	1/4" BSPP	Rear
PG63-25-04-PR	63	25	362	1/4" BSPP	Rear
PG63-40-04-PR	63	40	580	1/4" BSPP	Rear
PG63-60-04-PR	63	60	870	1/4" BSPP	Rear
PG63-100-04-PR	63	100	1450	1/4" BSPP	Rear
PG63-250-04-PR	63	250	3625	1/4" BSPP	Rear
PG63-400-04-PR	63	400	5801	1/4" BSPP	Rear
PG63-600-04-PR	63	600	8702	1/4" BSPP	Rear

All gauges have a Stainless Steel casing and are filled with glycerine.

Hydraulic Accessories

www.hardyspicer.com.au

Document No:	HSHYDCAT
Issue:	10
Issue Date:	01/09/2017

ACCESSORIES



MANOMETER PRESSURE GAUGES

Part Number	Diameter mm	Pressure		Thread	Thread Location
		Bar	PSI		
PG100-10-08-PB	100	10	145	1/2" BSPP	Bottom
PG100-25-08-PB	100	25	362	1/2" BSPP	Bottom
PG100-40-08-PB	100	40	580	1/2" BSPP	Bottom
PG100-100-08-PB	100	100	1450	1/2" BSPP	Bottom
PG100-250-08-PB	100	250	3625	1/2" BSPP	Bottom
PG100-400-08-PB	100	400	5801	1/2" BSPP	Bottom
PG100-600-08-PB	100	600	8702	1/2" BSPP	Bottom
PG100-10-08-PR	100	10	145	1/2" BSPP	Rear
PG100-25-08-PR	100	25	362	1/2" BSPP	Rear
PG100-40-08-PR	100	40	580	1/2" BSPP	Rear
PG100-100-08-PR	100	100	1450	1/2" BSPP	Rear
PG100-250-08-PR	100	250	3625	1/2" BSPP	Rear
PG100-400-08-PR	100	400	5801	1/2" BSPP	Rear
PG100-600-08-PR	100	600	8702	1/2" BSPP	Rear

All gauges have a Stainless Steel casing and are filled with glycerine.

FITTINGS & ADAPTORS FOR PRESSURE GAUGES

Part Number	Diameter mm	Description
Rubber Cover		
PG63-RUBBER	63	Rubber Protective Cover
PG100-RUBBER	100	Rubber Protective Cover
Flange to Convert Bottom Entry Gauge to Surface Mount		
PG63-FLANGE	63	Flange Bracket
PG100-FLANGE	100	Flange Bracket
3 Hole Flange to Convert Rear Entry Gauge to Panel Mount		
PG63-0606891	63	Flush Mount Ring
PG100-0606892	100	Flush Mount Ring
U-Clamp Bracket to Convert Rear Entry Gauge to Surface Mount		
PG63-BRACKET	63	Clamp Version Bracket
PG100-BRACKET	100	Clamp Version Bracket

www.hardyspicer.com.au

Document No:	HSHYDCAT
Issue:	10
Issue Date:	01/09/2017

ACCESSORIES

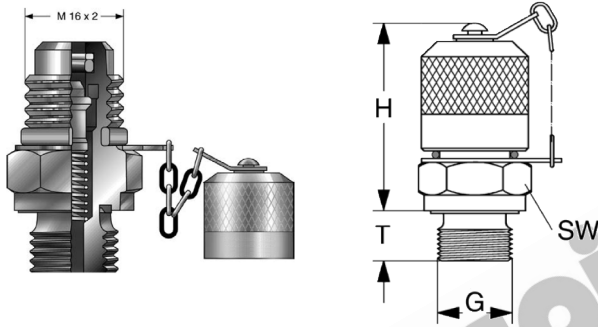

1620 SERIES TEST POINTS

Part Number	Pressure		Thread G	Height H (mm)	Thread Height T (mm)	Nut SW (mm)
	Bar	PSI				
TPF20-UNF07-PE	630	9000	7/16-20 UNF	37	9	17
TPF20-UNF09-PE	630	9000	9/16-18 UNF	37	10	19
TPF20-G02-PC	630	9000	1/8 BSPP	37	8	17
TPF20-G04-PC	630	9000	1/4 BSPP	37	12	19
TPF20-R02-PD	400	5800	1/8 BSPT	37	10	17
TPF20-R04-PD	630	9000	1/4 BSPT	37	12	19
TPF20-N02-PD	400	58000	1/8 NPTF	37	10	17
TPF20-N04-PD	630	9000	1/4 NPTF	37	14	19
TPF20-M10X1-PC	630	9000	M10X1	37	8.5	17
TPF20-JF07-FP	630	9000	7/16 JIC F	64		14
TPF20-JF09-FP	315	4500	9/16 JIC F	67		19

Hydraulic Accessories

www.hardyspicer.com.au

Document No:	HSHYDCAT
Issue:	10
Issue Date:	01/09/2017

ACCESSORIES

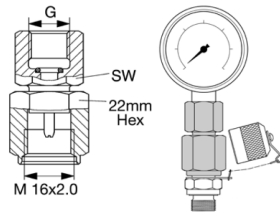

Fig 1

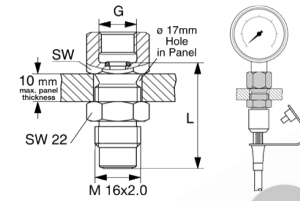

Fig 2

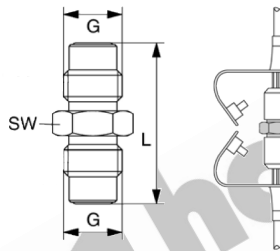

Fig 3

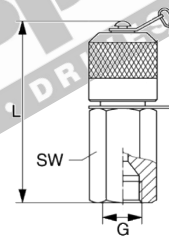

Fig 4

1620 SERIES TEST POINT ADAPTORS

Part Number	Pressure		Thread G	Figure	Length L (mm)	Nut SW (mm)
	Bar	PSI				
Direct Gauge Adaptor						
TEST-06003824	630	9000	ISO 228-G 1/4	1	-	19
TEST-06003825	630	9000	ISO 228-G 1/2	1	-	27
TEST-06003769	630	9000	1/4 NPT	1	-	19
Hose to Gauge Bulkhead Adaptor						
TEST-06003822	630	9000	ISO 228-G 1/4	2	38.5	19
TEST-06003823	630	9000	ISO 228-G 1/2	2	39.5	27
TEST-06003768	630	9000	1/4 NPT	2	38.5	19
Straight Coupling for Hose to Hose Connections						
TEST-0687889	630	9000	M16X2.0	3	42	22
Standpipe Adaptor 37° JIC Fitting						
TEST-06003792	630	9000	7/16"-20 UNF	4	55	17
TEST-06003793	420	6000	1/2"-20 UNF	4	55.5	17
TEST-06003794	315	4500	9/16"-18 UNF	4	57.5	19
TEST-06003795	315	4500	3/4"-16 UNF	4	60.5	22

www.hardyspicer.com.au

Document No:	HSHYDCAT
Issue:	10
Issue Date:	01/09/2017

ACCESSORIES

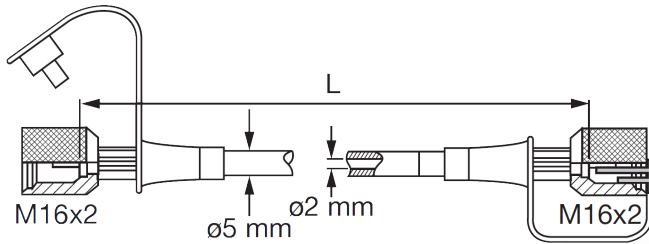

Specifications

- Maximum working pressure 9000 psi (630 BAR) at 122°F (50°C)
- Suitable for petroleum based fluids
- Temperature range -4° to 122°F (-20° to 50°C) at max. pressure
- Polyamid core with polyester braid reinforcement and polyamid jacket
- Plastic dust cap
- 1620 female connection at both ends
- Bend radius: 20mm minimum
- Hose ID is 2mm
- Custom hose assemblies available on request
NPT Male, NPT Female, JIC Male, JIC Female Swivel hose ends.

1620 SERIES MICRO BORE FLEXIBLE HOSES

Part Number	Length 'L'		Thread	Notes
	inches	mm		
TEST-HOSE-0200	8	200	M16x2	
TEST-HOSE-0300	12	300	M16x2	
TEST-HOSE-0400	16	400	M16x2	
TEST-HOSE-0500	20	500	M16x2	
TEST-HOSE-0600	24	600	M16x2	
TEST-HOSE-0800	31	800	M16x2	
TEST-HOSE-1000	39	1000	M16x2	
TEST-HOSE-1250	49	1250	M16x2	
TEST-HOSE-1500	59	1500	M16x2	
TEST-HOSE-2000	79	2000	M16x2	
TEST-HOSE-2500	98	2500	M16x2	
TEST-HOSE-3200	126	3200	M16x2	
TEST-HOSE-4000	157	4000	M16x2	
TEST-HOSE-5000	197	5000	M16x2	

Hydraulic Accessories

www.hardyspicer.com.au

Document No:	HSHYDCAT
Issue:	10
Issue Date:	01/09/2017

ACCESSORIES

HYDRAULIC OIL



ISO VISCOSITY 32

Part Number	Description	Qty Litres	Comments
OIL-32-1-RF	ISO Viscosity 32 (Refill)	1	
OIL-32-20-P	ISO Viscosity 32	20	
OIL-32-205-P	ISO Viscosity 32	205	

ISO VISCOSITY 46

Part Number	Description	Qty Litres	Comments
OIL-46-1-RF	ISO Viscosity 46 (Refill)	1	
OIL-46-20-P	ISO Viscosity 46	20	
OIL-46-205-P	ISO Viscosity 46	205	

ISO VISCOSITY 68

Part Number	Description	Qty Litres	Comments
OIL-68-1-RF	ISO Viscosity 68 (Refill)	1	
OIL-68-20-P	ISO Viscosity 68	20	
OIL-68-205-P	ISO Viscosity 68	205	

Other oil options available on request

www.hardyspicer.com.au

Document No:	HSHYDCAT
Issue:	10
Issue Date:	01/09/2017

ACCESSORIES



CABLE TIES

PART NUMBER	LENGTH inch / mm	WIDTH inch / mm	PACK QTY	COMMENTS
CT-10025BLK	3.937" / 100	0.098" / 2.50	100	
CT-15035BLK	5.905" / 150	0.138" / 3.50	100	
CT-20047BLK	7.874" / 200	0.185" / 4.70	100	
CT-30047BLK	11.811" / 300	0.185" / 4.70	100	
CT-37075BLK	14.567" / 370	0.295" / 7.50	100	
CT-38047BLK	14.961" / 380	0.185" / 4.70	100	
CT-53013BLK	20.866" / 530	0.512" / 13.00	25	
CT-55075BLK	21.653" / 550	0.295" / 7.50	50	

Other cable tie colour options available on request.



HOSE CLEANING PROJECTILES

Part Number		Hose Size		Approximate guide for use with Nozzle			
Standard	Coupling	Imperial	Metric (Nominal)	Hose / Tube No Fitting	BSP Fitting	JIC Fitting	Tube Fitting
S7	C7	1/4"	6mm	H06	B06	J06 / J08	T06
S10	C10	5/16"	8mm	H08	-	-	T08
S12	C12	3/8"	10mm	H10	B10	J10	T10
S16	C16	1/2"	13mm	H13	B13	J13	T13
S20	C20	5/8"	16mm	H16	B16	J16	T16
S22	C22	3/4"	19mm	-	B19	J19	T19
S24	C24	3/4"	19mm	H19	-	-	-
	C26	7/8"	22mm	-	-	-	T22
S30	C30	1"	25mm	H25	-	-	-
S33	C33	1"	25mm	-	B25	J25	T25
S40	C40	1 1/4"	32mm	H32 / T32	B32	J32	T32
S50	C50	1 1/2"	38mm	H38	B38	J38	T38
S60	C60	2"	50mm	H50	B50	J50	T50

www.hardyspicer.com.au

Document No:	HSHYDCAT
Issue:	10
Issue Date:	01/09/2017

ACCESSORIES

SPILL CONTROL

ABSORBENT SPONGE



Part No: **OIL-SP-SPONGE-Z**

Description: Absorption Mineral Sponge. 10kg pack.

Features: Inert mineral - No chemical additive
Absorbs immediately on contact
Super absorbent capacity
Exceeds EPA landfill leachate tests
De-Dusted to reduce surface bogging
Won't leach back absorbed fluids

ABSORBENT PADS



Part No: **OIL-SC01320** (Pack)

Description: Oil Spill Pad. Pack of 100. Heavy Duty Needle-Punched Poly.

Size: 430mm x 480mm x 400GSM.

Features: Flame resistant, non-toxic
Float even when fully saturated
Absorbs upto 100 ltrs per 100 pack

ABSORBENT ROLL



Part No: **OIL-SC01308**

Description: Oil Absorbent Roll. Perfed Heavy Duty Roll.

Size: 960mm x 43m.

Features: Ideal foot traffic mat along walkways
Perforated every 430mm for tear-off

ABSORBENT PILLOWS



Part No: **OIL-SC1851**

Description: Oil Spill Pillows. Pack of 12. Large Poly.

Size: 500mm x 400mm x 75mm.

Features: Ideal for waste troughs, coolant tanks, fluid reservoirs and sump wells

www.hardyspicer.com.au

Document No:	HSHYDCAT
Issue:	10
Issue Date:	01/09/2017

ACCESSORIES

ABSORBENT BOOMS



Mini Absorbent Booms			
Part No.	Description	Units	Size
OIL-SC01501	White Poly Mini Boom	12 Pack	75mm x 1.2m
OIL-SC01501-EA	White Poly Mini Boom	Each	75mm x 1.2m
OIL-SC01517	White K-Sorb Organic Boom	6 Pack	75mm x 3m
OIL-SC01517-EA	White K-Sorb Organic Boom	Each	75mm x 3m
Large Absorbent Floating Booms			
Part No.	Description	Units	Size
OIL-SC01726	White Floating Boom	4 Pack	125mm x 3m
OIL-SC01726-EA	White Floating Boom	Each	125mm x 3m
OIL-SC01727	White Floating Boom	4 Pack	125mm x 6m

DRAIN WARDEN



- Part No: **OIL-SC13001**
- Description: Drain Warden.
Standard deep basin with bilge rat.
- Size: 1200mm x 1200mm x 560mm deep.
- Features: Designed to catch oil and sediment run off before it enters the storm water system.

WASTE DISPOSAL BAGS



- Part No: **OIL-SC02701**
- Description: Yellow Contaminated Waste Disposal Bag.
- Size: 560mm x 990mm High.
- Features: Strong poly bags.

PROTECTIVE GLOVES



- Part No: **OIL-SC15081**
- Description: Nitrile Protective Gloves.
- Features: Chemical resistant.

Hydraulic Accessories

www.hardyspicer.com.au

Document No:	HSHYDCAT
Issue:	10
Issue Date:	01/09/2017

ACCESSORIES

SPILL KITS



Part No: **OIL-SP-KIT**

Description: Oil Spill Control Kit.
Carry Bag Type.

Contents: 1 x Blue Carry Bag
1 x 2kg Bag Spill Sponge Floor Sweep
2 x K-Sorb Mini Booms 75mm x 1.2m
5 x Absorbent Pads 430mm x 480mm
1 x Pair of Nitrile Industrial Gloves
1 x Yellow Disposal Bag & Cable Tie
Material Safety Data Sheets
Spill Instruction Sheet



Part No: **OIL-SP-KIT240LT**

Description: Oil Spill Control Kit.
Wheelie Bin Type.

Contents: 1 x Yellow 240Lt Wheelie Bin
50 x Absorbent Pads 430mm x 480mm
5 x K-Sorb Mini Booms 75mm x 1.2m
2 x Absorbent Pillows 500mm x 400mm
1 x Pair of Nitrile Industrial Gloves
5 x Yellow Disposal Bag & Cable Tie
2 x 20kg Bag Spill Sponge Floor Sweep
Spill Instruction Sheet

www.hardyspicer.com.au

Document No:	HSHYDCAT
Issue:	10
Issue Date:	01/09/2017

ACCESSORIES

HYDRAULIC FITTING TEMPLATES



- Part No:** TEMPLATE-GATES
- Description:** Three Templates to Identify Fittings, Hose and Tube. 428-7108
- Features:** Providing a fast and easy method of identifying threads.

THREAD IDENTIFICATION KIT



- Part No:** THREAD-ID-KIT
- Description:** Thread identification kit. 7369-4318
- Contents:** Callipers, Seat Gauges (Metric & Imp), Thread Gauges and Thread I.D. Book.

DIGITAL CALIPERS



- Part No:** DIGITAL-CALIPERS
- Description:** 6" Digital Calipers. 7369-0322
- Features:** Stainless steel calipers with easy to read LCD screen. Including protective carry case.

GATES SAFE HYDRAULICS PROGRAM

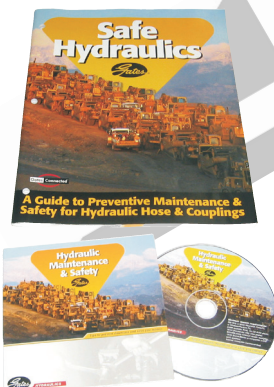

- Description:** Gates Safe Hydraulics Training Program
- Features:** The Gates Hydraulic Safety and Preventive Maintenance Program helps you cut costs and prevent injuries from hydraulic assembly failures. Contact Hardy Spicer to arrange this hands-on two hour seminar that is offered to qualified organisations. Topics include inspection procedures, troubleshooting, hose and fitting selection, hose assembly and equipment maintenance.

www.hardyspicer.com.au

Document No:	HSHYDCAT
Issue:	10
Issue Date:	01/09/2017

Hydraulic Accessories

ACCESSORIES**HOSE PERFORATOR**Part No: **7482-6565**

Description: Hand Operated Hose Perforator.

Size: 1 1/4"
Suit hoses from 3/16" - 3/4"

Features: Needle studded wooden roller to perforate hose covers used in high pressure inert gas applications.

Part No: **7482-6566**

Description: Hand Operated Hose Perforator.

Size: 3"
Suit hoses from 1" - 2"

Features: Needle studded wooden roller to perforate hose covers used in high pressure inert gas applications.

HAND HELD HOSE CUTTERPart No: **CUTTER-HAND**

Description: Hand cutter.

Features: Cuts most non-metal reinforced rubber hoses. Blades folds back into a lightweight nylon handle for safety.

Blade: Replacement Blade - **7469-0144**www.hardyspicer.com.au

Document No:	HSHYDCAT
Issue:	10
Issue Date:	01/09/2017

ACCESSORIES

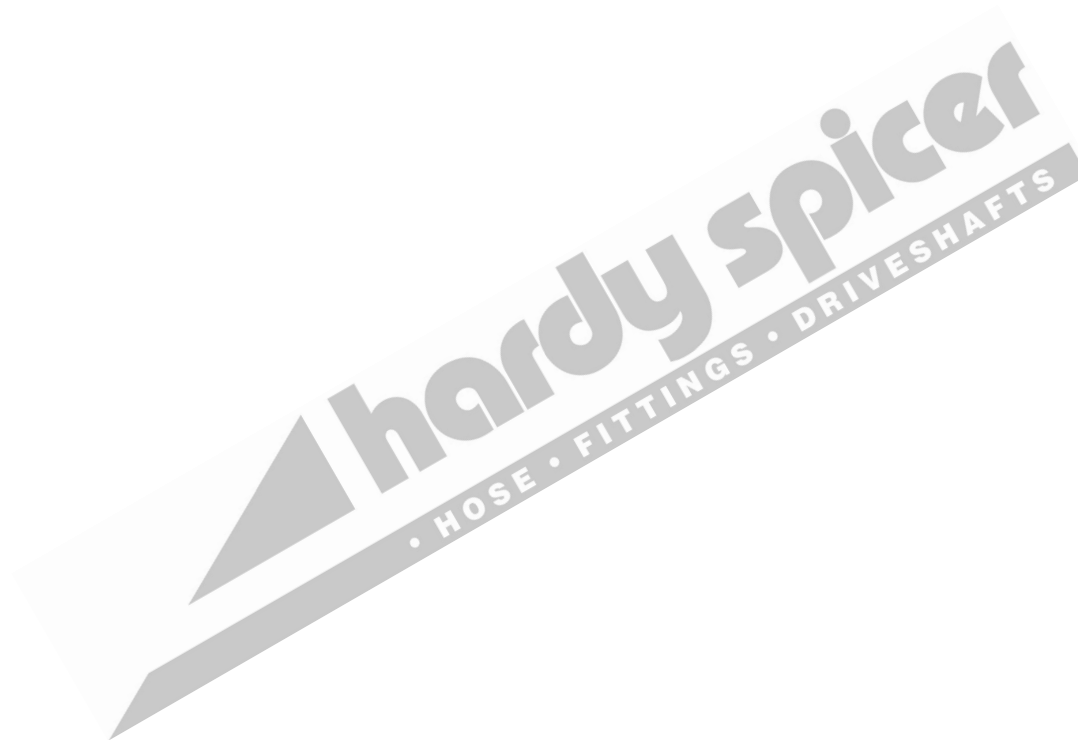

Hydraulic Accessories

www.hardyspicer.com.au

Document No:	HSHYDCAT
Issue:	10
Issue Date:	01/09/2017

ACCESSORIES

GC32-XD CRIMPER



Part No: **GC32-XD**

Description: Powerful hydraulic crimper

Features: The new GC32-XD crimper crimps fittings up to 2 1/2". The open crimper head accommodates most hose construction or fitting configuration. The unique cloverleaf® design produces a smoother, better and more consistent crimp without any tapers in the crimp OD. A quick change tool enables fast loading of the colour coded, numbered dies.

Power Source: Single phase 20 amp plug

POWER CRIMP 707



Part No: **PC707-240V**

Description: Versatile mobile crimper.

Features: The most precise, yet simplest crimper made. Includes electronic digital readout to indicate crimp diameter setting. Crimps low pressure return lines to high pressure spiral hoses from 3/16" to 1-1/4" 4 wire spiral hose. Suitable for crimping straight and bent tube fittings as well as 45° & 90° block types.

www.hardyspicer.com.au

Document No:	HSHYDCAT
Issue:	10
Issue Date:	01/09/2017

Other crimpers available on request

ACCESSORIES**HOSE CUT-OFF SAWS****HOSE CUTTER 6-32**Part No: **CUTTER-6-32**

Description: Powerful hose cutter.



Features: Cuts up to 2" ID 2 wire through to 6-Spiral reinforced hose. Reversible 10" scalloped-edge high speed steel blade with 3/4" bore. Radius hose feed into blade for reduced friction. Power cord supplied with 220V 20 amps, AC plug which can be removed for hard wire applications. Includes coolant spray system kit for reduced heat in high-capacity cutting applications.

Power Source: 3 HP (5.2 HP Peak), single phase, 230V 60Hz., 15 amp motor with power cord and plug.

Replacement Blade: **CUTTER-6-32-BL****HOSE SAW (12V / 24V / 240V)**Part No: **HOSE SAW-12V
HOSE SAW-24V
HOSE SAW-240V**

Description: Versatile hose cutter.



Features: Cuts up to 1 1/4" ID 4 wire spiral hose & up to 2" 2 wire braided hose. Comes with a 10" toothed blade. Radius hose feed into blade for reduced friction. Available in three power sources, 12, 24 & 240 volts

Replacement Blade: **CHEETAH-BLADE**

Other cut-off saws available on request

www.hardyspicer.com.au

Document No:	HSHYDCAT
Issue:	10
Issue Date:	01/09/2017

Hydraulic Accessories

ACCESSORIES

NOTES

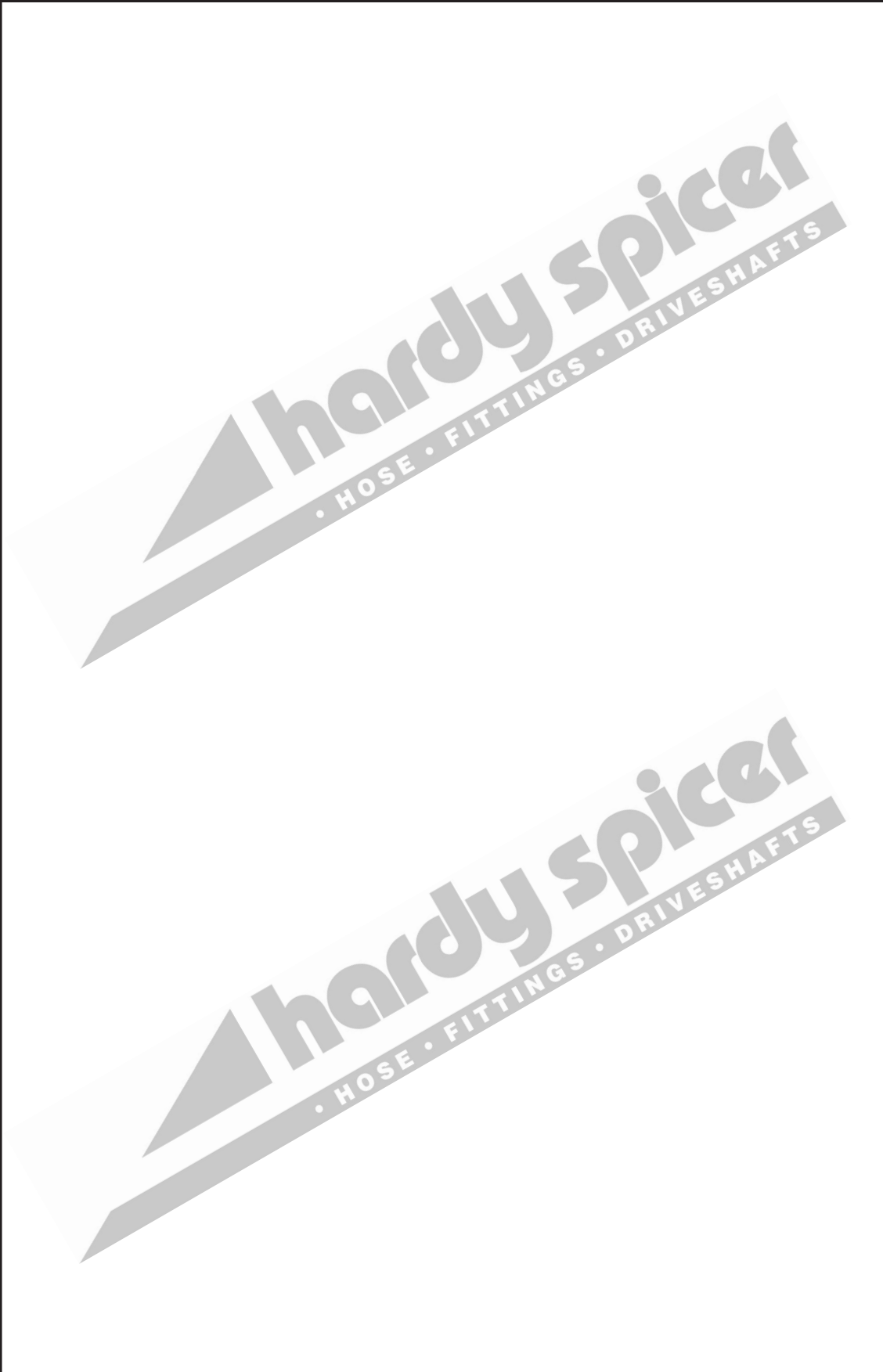

www.hardyspicer.com.au

Document No:	HSHYDCAT
Issue:	10
Issue Date:	01/09/2017

ACCESSORIES

NOTES

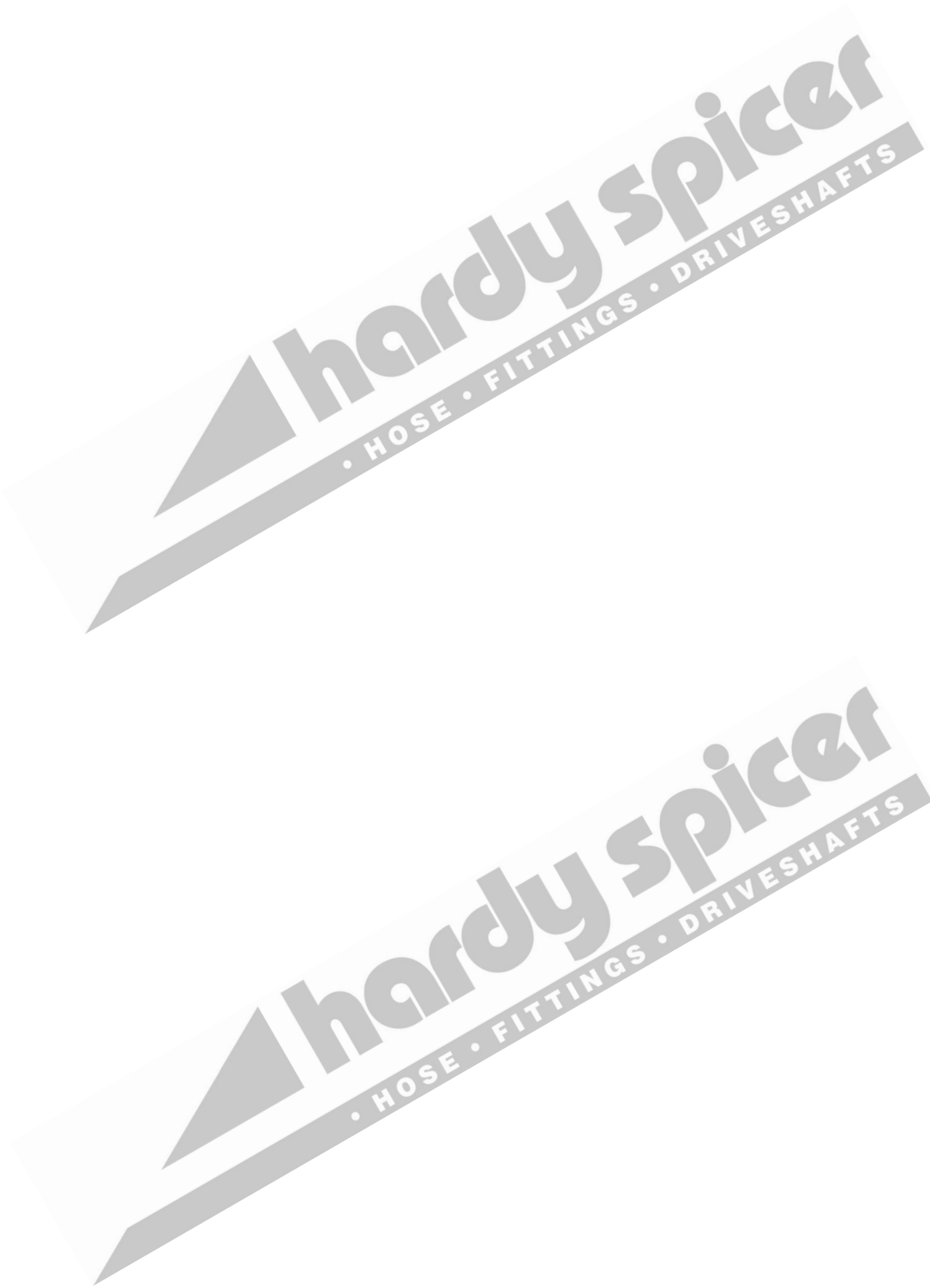

Hydraulic Accessories

www.hardyspicer.com.au

Document No:	HSHYDCAT
Issue:	10
Issue Date:	01/09/2017